



QPix Bar

LED BAR 40 LEDS RGB + CONTROLLER

Order code: SG QPIXBAR (LED Bar)
SG QPIXBARBOX (Controller)

**MANUALE UTENTE
USER MANUAL**





INDICE:

<u>1. INTRODUZIONE</u>	<u>p. 3</u>
<u>2. ISTRUZIONI DI SICUREZZA</u>	<u>p. 4</u>
<u>3. APERTURA CONFEZIONE E CONTROLLO</u>	<u>p. 6</u>
<u>4. INSTALLAZIONE ED ACCENSIONE</u>	<u>p. 8</u>
<u>5. ISTRUZIONI PER L'USO</u>	<u>p. 10</u>
<u>6. MANUTENZIONE</u>	<u>p. 15</u>
<u>7. SPECIFICHE TECNICHE</u>	<u>p. 16</u>

INDEX:

<u>1. INTRODUCTION</u>	<u>p. 17</u>
<u>2. SAFETY INSTRUCTIONS</u>	<u>p. 18</u>
<u>3. OPENING AND CONTROL</u>	<u>p. 20</u>
<u>4. INSTALLATION AND SWITCH ON</u>	<u>p. 22</u>
<u>5. SETUP</u>	<u>p. 24</u>
<u>6. MAINTENANCE</u>	<u>p. 29</u>
<u>7. TECHNICAL SPECIFICATIONS</u>	<u>p. 30</u>



1. INTRODUZIONE

Grazie per avere scelto un nostro prodotto!

Vi preghiamo di fare riferimento alle istruzioni e alle avvertenze contenute nel presente manuale per l'utilizzo del dispositivo e di conservarlo per future consultazioni.

Il presente manuale contiene informazioni riguardanti l'installazione e l'utilizzo del dispositivo. Le informazioni contenute in questo documento sono state attentamente redatte e controllate. Tuttavia non è assunta alcuna responsabilità per eventuali inesattezze. Tutti i diritti sono riservati e questo documento non può essere copiato, fotocopiato, riprodotto o per intero o in parte senza previo consenso scritto della PROEL. PROEL si riserva il diritto di apportare senza preavviso cambiamenti e modifiche estetiche, funzionali o di design a ciascun proprio prodotto. PROEL non assume alcuna responsabilità sull'uso o sull'applicazione dei prodotti qui descritti.



Il simbolo del cassonetto barrato, riportato sul prodotto o sulla documentazione, indica che il prodotto non deve essere smaltito con altri rifiuti domestici al termine del ciclo di vita. Per evitare eventuali danni all'ambiente si invita l'utente a separare questo prodotto da altri tipi di rifiuti e di riciclarlo in maniera responsabile per favorire il riutilizzo sostenibile delle risorse materiali. Gli utenti domestici sono invitati a contattare il rivenditore presso il quale è stato acquistato il prodotto o l'ufficio locale preposto per tutte le informazioni relative alla raccolta differenziata e al riciclaggio per questo tipo di prodotto. Gli utenti aziendali sono invitati a contattare il proprio fornitore e verificare i termini e le condizioni del contratto di acquisto. Questo prodotto non deve essere smaltito unitamente ad altri rifiuti commerciali.



Il simbolo del lampo con freccia in un triangolo equilatero intende avvertire l'utilizzatore della presenza di "tensioni elettriche pericolose" non isolate all'interno dell'involucro del prodotto, che possono avere una intensità sufficiente a costituire rischio di scossa elettrica alle persone.



Il punto esclamativo in un triangolo equilatero intende avvertire l'utilizzatore della presenza di importanti istruzioni per l'utilizzo e la manutenzione nella documentazione che accompagna il prodotto.



Il simbolo della F indica che è consentito il montaggio dell'apparecchio su superfici normalmente infiammabili.



Il prodotto a cui questo manuale si riferisce è conforme alle Direttive Europee di cui sono oggetto relative alla sicurezza delle apparecchiature alimentate in Bassa Tensione (LVD) ed alla compatibilità elettromagnetica (EMC)



2. ISTRUZIONI DI SICUREZZA

Attenzione! Questo prodotto non è adatto ad un uso domestico.

Leggere il presente manuale prima di installare e dare corrente all'apparecchiatura, seguire le precauzioni di sicurezza elencate di seguito ed osservare tutti gli avvertimenti indicati nel presente manuale e stampati sull'apparecchiatura. Si prega di contattare un distributore PROEL per ricevere assistenza riguardo qualsiasi dubbio su come attivare l'apparecchiatura in modo sicuro. Rivolgersi ad un tecnico qualificato per qualsiasi operazione di manutenzione non descritta nel presente manuale.

Non modificare l'apparecchiatura e non installare accessori e kit di aggiornamento che non siano quelli originali PROEL.

Le persone coinvolte nell'installazione e nella manutenzione del dispositivo devono:

- Essere qualificate
- Seguire le istruzioni del presente manuale nei teatri, nelle sale, nei luoghi in cui si svolgono gli eventi, ecc.

VERIFICHE PRIMA DELL'INSTALLAZIONE

Assicurarsi che tutte le parti per il fissaggio del prodotto siano in buone condizioni.

Assicurarsi che il punto di ancoraggio sia stabile prima di posizionare il prodotto.

Il cavo di sicurezza deve essere debitamente agganciato al dispositivo e fissato alla struttura di sostegno in modo che, in caso di cedimento del sistema di supporto primario, si abbia la minore caduta possibile del dispositivo.

Se il cavo di sicurezza si usura, deve essere sostituito con un ricambio originale.

DISTANZA MINIMA DEGLI OGGETTI ILLUMINATI

Il proiettore deve essere posizionato in modo tale che gli oggetti investiti dal fascio di luce siano ad almeno 2 metri dalle lenti del proiettore.

DISTANZA MINIMA DA MATERIALI INFIAMMABILI

Il prodotto deve essere posizionato in modo tale che qualsiasi materiale infiammabile sia ad almeno 0,50 metri da qualsiasi punto della superficie del dispositivo. Non porre mai filtri o altri materiali sopra le lenti o sull'asse ottico.

SUPERFICI DI MONTAGGIO

Adatto per il montaggio su superfici con caratteristiche ignifughe normali e/o infiammabili.

TEMPERATURE DI RIFERIMENTO

Il range di temperatura ambiente d'utilizzo del dispositivo varia tra +5°C (min) e +40°C (max), al di fuori di tale intervallo l'apparecchio non deve essere utilizzato.

La temperatura massima dell'alloggiamento $T_b=80^{\circ}\text{C}$ non deve mai essere superata. Non ostruire le ventole di scarico, garantire uno spazio libero di almeno 0,5 metri attorno ai fori di aerazione.



CLASSE DI PROTEZIONE IP20

Il dispositivo è protetto contro la penetrazione di corpi solidi di dimensioni superiori a 12 mm (0.47") di diametro (prima cifra 2), ma non contro la caduta di gocce d'acqua, pioggia, schizzi o getti d'acqua (seconda cifra 0).

Usare solo in ambienti asciutti. Usare solo all'interno.

Non esporre l'apparecchiatura a pioggia o ad umidità.

PROTEZIONE CONTRO LE SCOSSE ELETTRICHE

Il dispositivo deve essere collegato ad un sistema di alimentazione dotato di un'efficiente messa a terra. Inoltre, si consiglia di proteggere le linee di alimentazione del prodotto dai contatti indiretti e/o da cortocircuiti verso massa utilizzando interruttori differenziali opportunamente dimensionati.

COLLEGAMENTO ALLA RETE DI ALIMENTAZIONE

Il collegamento alla rete elettrica deve essere effettuato da un installatore elettrotecnico qualificato.

Assicurarsi che la frequenza di rete e la tensione corrispondano a quelle per le quali l'apparecchio è progettato, come indicato nella targhetta dei dati elettrici. Tale targhetta indica anche la potenza assorbita a cui è necessario fare riferimento per valutare il numero massimo di dispositivi da collegare alla linea elettrica, al fine di evitare sovraccarichi.

Se il cavo di alimentazione esterno di questa apparecchiatura da illuminazione è danneggiato, deve essere sostituito con un cavo speciale, disponibile esclusivamente presso i rivenditori PROEL.

Non attivare mai l'apparecchiatura con lenti e/o coperture mancanti o danneggiate.

In caso di non utilizzo, si consiglia di scollegare il proiettore dalla rete elettrica.

MANUTENZIONE

Prima di iniziare qualsiasi operazione di manutenzione o pulire il prodotto, togliere la tensione dalla rete di alimentazione e scollegare il cavo dal dispositivo.

Dopo lo spegnimento non rimuovere alcuna parte del dispositivo per almeno 35 minuti onde evitare il rischio di bruciature.

Le lenti, se danneggiate, devono essere sostituite con ricambi originali.

AVVERTENZE

ATTENZIONE. Non guardare direttamente la fonte luminosa.

Non guardare il fascio di luce con lenti, occhiali, specchi o strumenti ottici simili che potrebbero modificare la convergenza di luce, arrecando gravi danni a persone e/o cose.



ATTENZIONE! PERICOLO PER GLI OCCHI!

Non guardare direttamente la fonte di luce



3. APERTURA DELLA CONFEZIONE E CONTROLLO

Aprire con cura la confezione, verificare il contenuto e assicurarsi che tutte le parti siano presenti e siano in buone condizioni. Nel caso in cui alcune parti non siano presenti o siano danneggiate, contattare immediatamente il proprio fornitore e conservare l'imballaggio per la verifica.

	<p>ATTENZIONE!</p> <p>Se l'apparecchio è stato esposto a drastici sbalzi di temperatura, lasciare spenta l'unità finché non raggiunge la temperatura ambiente in quanto la presenza di condensa potrebbe danneggiare il prodotto se acceso.</p>
---	--

Controllare che le scatole contengano i seguenti articoli:

Scatola della barra :

- N° 1 SG QPIXBAR
- N°1 Filtro frost bianco
- N°1 Cavo Cat5

Scatola del CONTROLLER :

- N° 1 SG QPIXBARBOX
- N°1 Cavo di alimentazione
- N°1 Cavo Cat5
- N°1 Cavo DMX

BARRA VISTA FRONTALE

1

1 – Filtro frost nero



BARRA VISTA POSTERIORE

1

1 – Segnale + Alimentazione IN

2 – Segnale + Alimentazione OUT

2





CONTROLLER VISTA FRONTALE

1. Ingresso alimentazione
2. Rilancio alimentazione
3. Fusibile
4. Pulsante accensione
5. Display + pulsantiera
6. Indicatore segnale DMX

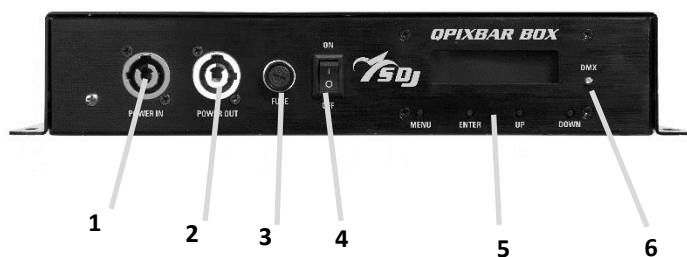

CONTROLLER VISTA POSTERIORE

1. DMX IN XLR 5 poli
2. DMX IN XLR 3 poli
3. Ingressi ArtNet
4. DMX OUT XLR 3 poli
5. DMX OUT XLR 5 poli
6. Uscite barre A-B-C-D: alimentazione + segnale (solo barre)



	<p style="text-align: center;"><u>ATTENZIONE !!!</u></p> <p>Non collegare il cavo ArtNet proveniente da un PC o consolle alle uscite OUT A-B-C-D in quanto su tali uscite è presente anche l'alimentazione VDC per le barre unitamente al segnale di comando.</p> <p>Il collegamento accidentale del cavo ArtNet del PC o della consolle ad una delle 4 uscite A-B-C-D può irrimediabilmente danneggiare lo stesso PC o la consolle</p>
--	--



4. INSTALLAZIONE ED ACCENSIONE

4.1 - INSTALLAZIONE PRODOTTO

- Non scuotere l'apparecchio. Evitare l'utilizzo di forza eccessiva durante le operazioni di installazione o fissaggio dell'unità.
- L'unità può essere installata, a parete, a soffitto o su truss, tramite la staffa posteriore.
- E' possibile creare differenti configurazioni utilizzando i seguenti accessori venduti separatamente

- IN CASO DI SOSPENSIONE A PARETE O A SOFFITTO, OGNI BARRA DEVE ESSERE FISSATA TRAMITE LA PROPRIA STAFFA A "C". NON E' POSSIBILE REALIZZARE MATRICI, FIGURE O COLONNE, SOSPENDENDO LE BARRE SOLO TRAMITE GLI ACCESSORI SEGUENTI O QUELLI GIA' INCLUSI



SG QPIXBARCK2
Connessione 2 vie 90°



SG QPIXBARCK3
Connessione 3 vie a "T"



SG QPIXBARCK4
Connessione 4 vie



SG QPIXBARCKV
Connessione 2 vie variabile

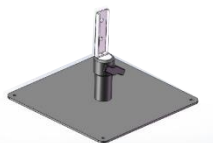

SG QIXBARBS
Base per 2 barre in verticale



SG QPIXBARRWD
Diffusore bianco circolare

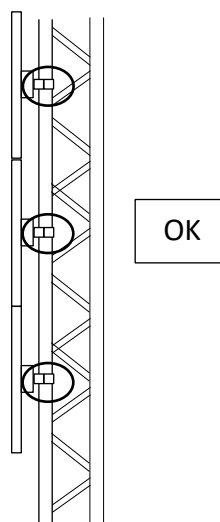
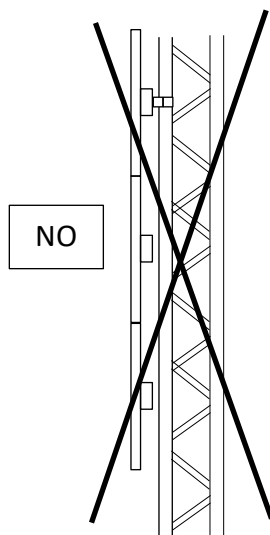

ATTENZIONE! E' OBBLIGATORIO

il montaggio della fune di sicurezza (PLH232 – PLH248 vendute separatamente) nel caso in cui il prodotto sia appeso a parete, a soffitto o su truss. Il montaggio del cavo di sicurezza è obbligatorio.



4.2 - COLLEGAMENTO ALLA LINEA DI ALIMENTAZIONE

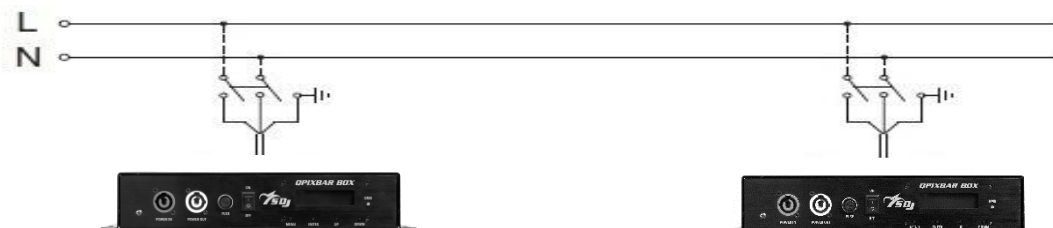

Il dispositivo deve essere collegato ad un sistema di alimentazione dotato di un'efficiente messa a terra. Inoltre, si consiglia di proteggere le linee di alimentazione dei prodotti dai contatti indiretti e/o da cortocircuiti verso massa utilizzando interruttori differenziali opportunamente dimensionati.

Il collegamento alla rete elettrica deve essere effettuato da un installatore elettrotecnico qualificato.

Assicurarsi che la frequenza di rete e la tensione corrispondano a quelle per le quali il dispositivo è progettato, come indicato nella targhetta dei dati elettrici.

4.3 - COLLEGAMENTO ALLA CATENA DMX

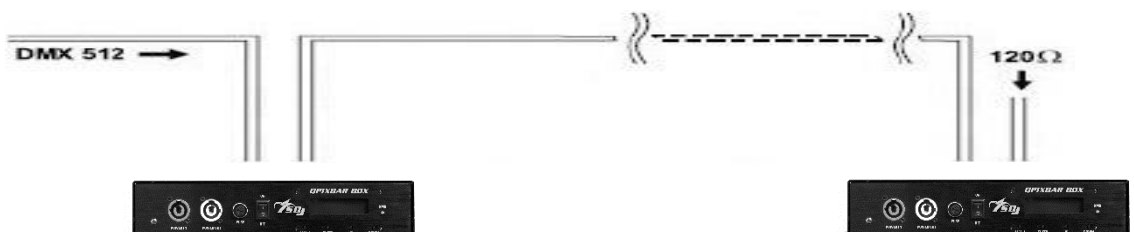

Utilizzare un cavo conforme alle specifiche EIA RS-485: bipolare intrecciato, schermato, 120Ohm di impedenza caratteristica e bassa capacità (SAGITTER SG DMX3 – SG DMX5).

Non utilizzare cavo microfonico o altro cavo con caratteristiche diverse da quelle specificate. Le terminazioni devono essere effettuate con connettori maschio/femmina tipo XLR a 3 pin. È necessario inserire sull'ultimo apparecchio uno spinotto terminale con una resistenza da 120Ohm (minimo 1/4 W) tra i terminali 2 e 3.

IMPORTANTE: I cavi non devono entrare in contatto tra di loro o con l'involucro metallico dei connettori. L'involucro stesso deve essere collegato alla calza di schermo ed al piedino 1 dei connettori.



5. ISTRUZIONI PER L'USO

5.1 – MAPPA DEL MENU'

Livello	Funzione	Opzioni	Descrizione
1	DMX address	001 – 512	Indirizzo DMX
2	DMX mode	CH7 / CH16 / CH48 / CH82 / CH480	Modalità canali
3	Auto mode	Speed 1 – 9	Velocità programmi interni
		Program 1 – 30	Scelta programma interno
4	Slave mode	YES / NO	Impostazione modalità Slave
5	Network settings	IP address: 0.0.0.0 – 255.255.255.255	Impostazione ArtNet
		Subnet mask: 0.0.0.0 – 255.255.255.255	
		Net subnet univers: 000.00.00 – 255.15.15	
6	ArtNet Output	A	Uscita ArtNet
		A+B	
		A+B+C	
		A+B+C+D	
7	System reset	Reset	Reset
8	Software version	QPIXBAR V1.0	Versione Software

5.2 – MODALITA' MASTER/SLAVE

In questa modalità possono essere collegate più controller insieme come un'unica catena e funzionare in modo sincronizzato.

- Utilizzare un cavo DMX per collegare insieme tutte le unità dal connettore DMX OUT a DMX IN.
- Definire la prima unità della catena come Master, tutte le altre unità devono essere impostate in modalità SLAVE MODE = YES.
- Far funzionare l'unità Master in modalità Automatica (Auto Mode) per far funzionare l'intero sistema. L'intera catena di unità Slave si comporterà come l'unità Master.



5.3 – MODALITA' DMX

Modalità 7 canali

Canale	Valore	Descrizione
1	000 - 255	Master dimmer
2	000 - 255	Strobo da lento a veloce
3	000 - 255	Rosso (tutte le barre)
4	000 - 255	Verde (tutte le barre)
5	000 - 255	Blu (tutte le barre)
6	000 - 255	Programmi automatici (da 1 a 30)
7	000 - 255	Velocità programmi automatici

Modalità 16 canali (rif. disegno 1)

Canale	Valore	Descrizione
1	000 – 255	Master dimmer
2	000 – 255	Strobo da lento a veloce
3	000 – 255	Rosso: B1L1 + B1L2 + B1L3 + B1L4
4	000 – 255	Verde: B1L1 + B1L2 + B1L3 + B1L4
5	000 – 255	Blu: B1L1 + B1L2 + B1L3 + B1L4
6	000 – 255	Rosso: B2L1 + B2L2 + B2L3 + B2L4
7	000 – 255	Verde: B2L1 + B2L2 + B2L3 + B2L4
8	000 – 255	Blu: B2L1 + B2L2 + B2L3 + B2L4
9	000 – 255	Rosso: B3L1 + B3L2 + B3L3 + B3L4
10	000 – 255	Verde: B3L1 + B3L2 + B3L3 + B3L4
11	000 – 255	Blu: B3L1 + B3L2 + B3L3 + B3L4
12	000 – 255	Rosso: B4L1 + B4L2 + B4L3 + B4L4
13	000 – 255	Verde: B4L1 + B4L2 + B4L3 + B4L4
14	000 – 255	Blu: B4L1 + B4L2 + B4L3 + B4L4
15	000 – 255	Programmi automatici (da 1 a 30)
16	000 – 255	Velocità programmi automatici

Modalità 48 canali (rif. disegno 1)

Canale	Valore	Descrizione
1	000 – 255	Rosso: B1L1
2	000 – 255	Verde: B1L1
3	000 – 255	Blu: B1L1
4	000 – 255	Rosso: B2L1
5	000 – 255	Verde: B2L1
6	000 – 255	Blu: B2L1
7	000 – 255	Rosso: B3L1
8	000 – 255	Verde: B3L1
9	000 – 255	Blu: B3L1
10	000 – 255	Rosso: B4L1
11	000 – 255	Verde: B4L1
12	000 – 255	Blu: B4L1
13	000 – 255	Rosso: B1L2
14	000 – 255	Verde: B1L2
15	000 – 255	Blu: B1L2
16	000 – 255	Rosso: B2L2
17	000 – 255	Verde: B2L2
18	000 – 255	Blu: B2L2
19	000 – 255	Rosso: B3L2
20	000 – 255	Verde: B3L2



21	000 – 255	Blu: B3L2
22	000 – 255	Rosso: B4L2
23	000 – 255	Verde: B4L2
24	000 – 255	Blu: B4L2
25	000 – 255	Rosso: B1L3
26	000 – 255	Verde: B1L3
27	000 – 255	Blu: B1L3
28	000 – 255	Rosso: B2L3
29	000 – 255	Verde: B2L3
30	000 – 255	Blu: B2L3
31	000 – 255	Rosso: B3L3
32	000 – 255	Verde: B3L3
33	000 – 255	Blu: B3L3
34	000 – 255	Rosso: B4L3
35	000 – 255	Verde: B4L3
36	000 – 255	Blu: B4L3
37	000 – 255	Rosso: B1L4
38	000 – 255	Verde: B1L4
39	000 – 255	Blu: B1L4
40	000 – 255	Rosso: B2L4
41	000 – 255	Verde: B2L4
42	000 – 255	Blu: B2L4
43	000 – 255	Rosso: B3L4
44	000 – 255	Verde: B3L4
45	000 – 255	Blu: B3L4
46	000 – 255	Rosso: B4L4
47	000 – 255	Verde: B4L4
48	000 – 255	Blu: B4L4

Modalità 82 canali (rif. disegno 1)

Canale	Valore	Descrizione
1	000 – 255	Master dimmer B1L1
2	000 – 255	Strobo da lento a veloce B1L1
3	000 – 255	Rosso: B1L1
4	000 – 255	Verde: B1L1
5	000 – 255	Blu: B1L1
6	000 – 255	Master dimmer B2L1
7	000 – 255	Strobo da lento a veloce B2L1
8	000 – 255	Rosso: B2L1
9	000 – 255	Verde: B2L1
10	000 – 255	Blu: B2L1
11	000 – 255	Master dimmer B3L1
12	000 – 255	Strobo da lento a veloce B3L1
13	000 – 255	Rosso: B3L1
14	000 – 255	Verde: B3L1
15	000 – 255	Blu: B3L1
16	000 – 255	Master dimmer B4L1
17	000 – 255	Strobo da lento a veloce B4L1
18	000 – 255	Rosso: B4L1
19	000 – 255	Verde: B4L1
20	000 – 255	Blu: B4L1
21	000 – 255	Master dimmer B1L2



22	000 – 255	Strobo da lento a veloce B1L2
23	000 – 255	Rosso: B1L2
24	000 – 255	Verde: B1L2
25	000 – 255	Blu: B1L2
26	000 – 255	Master dimmer B2L2
27	000 – 255	Strobo da lento a veloce 2B2L2
28	000 – 255	Rosso: B2L2
29	000 – 255	Verde: B2L2
30	000 – 255	Blu: B2L2
31	000 – 255	Master dimmer B3L2
32	000 – 255	Strobo da lento a veloce B3L2
33	000 – 255	Rosso: B3L2
34	000 – 255	Verde: B3L2
35	000 – 255	Blu: B3L2
36	000 – 255	Master dimmer B4L2
37	000 – 255	Strobo da lento a veloce B4L2
38	000 – 255	Rosso: B4L2
39	000 – 255	Verde: B4L2
40	000 – 255	Blu: B4L2
41	000 – 255	Master dimmer B1L3
42	000 – 255	Strobo da lento a veloce B1L3
43	000 – 255	Rosso: B1L3
44	000 – 255	Verde: B1L3
45	000 – 255	Blu: B1L3
46	000 – 255	Master dimmer B2L3
47	000 – 255	Strobo da lento a veloce B2L3
48	000 – 255	Rosso: B2L3
49	000 – 255	Verde: B2L3
50	000 – 255	Blu: B2L3
51	000 – 255	Master dimmer B3L3
52	000 – 255	Strobo da lento a veloce B3L3
53	000 – 255	Rosso: B3L3
54	000 – 255	Verde: B3L3
55	000 – 255	Blu: B3L3
56	000 – 255	Master dimmer B4L3
57	000 – 255	Strobo da lento a veloce B4L3
58	000 – 255	Rosso: B4L3
59	000 – 255	Verde: B4L3
60	000 – 255	Blu: B4L3
61	000 – 255	Master dimmer B1L4
62	000 – 255	Strobo da lento a veloce B1L4
63	000 – 255	Rosso: B1L4
64	000 – 255	Verde: B1L4
65	000 – 255	Blu: B1L4
66	000 – 255	Master dimmer B2L4
67	000 – 255	Strobo da lento a veloce B2L4
68	000 – 255	Rosso: B2L4
69	000 – 255	Verde: B2L4
70	000 – 255	Blu: B2L4
71	000 – 255	Master dimmer B3L4
72	000 – 255	Strobo da lento a veloce B3L4
73	000 – 255	Rosso: B3L4
74	000 – 255	Verde: B3L4



75	000 – 255	Blu: B3L4
76	000 – 255	Master dimmer B4L4
77	000 – 255	Strobo da lento a veloce B4L4
78	000 – 255	Rosso: B4L4
79	000 – 255	Verde: B4L4
80	000 – 255	Blu: B4L4
81	000 – 255	Programmi automatici (da 1 a 30)
82	000 – 255	Velocità programmi automatici

Modalità 480 canali (rif. disegno 2)

Canale	Valore	Descrizione
1	000 – 255	Rosso: Px1B1L1 + Px1B1L2 + Px1B1L3 + Px1B1L4
2	000 – 255	Verde: Px1B1L1 + Px1B1L2 + Px1B1L3 + Px1B1L4
3	000 – 255	Blu: Px1B1L1 + Px1B1L2 + Px1B1L3 + Px1B1L4
4	000 – 255	Rosso: Px2B1L1 + Px2B1L2 + Px2B1L3 + Px2B1L4
5	000 – 255	Verde: Px2B1L1 + Px2B1L2 + Px2B1L3 + Px2B1L4
6	000 – 255	Blu: Px2B1L1 + Px2B1L2 + Px2B1L3 + Px2B1L4
...
118	000 – 255	Rosso: Px40B1L1 + Px40B1L2 + Px40B1L3 + Px40B1L4
119	000 – 255	Verde: Px40B1L1 + Px40B1L2 + Px40B1L3 + Px40B1L4
120	000 – 255	Blu: Px40B1L1 + Px40B1L2 + Px40B1L3 + Px40B1L4
121	000 – 255	Rosso: Px1B2L1 + Px1B2L2 + Px1B2L3 + Px1B2L4
122	000 – 255	Verde: Px1B2L1 + Px1B2L2 + Px1B2L3 + Px1B2L4
123	000 – 255	Blu: Px1B2L1 + Px1B2L2 + Px1B2L3 + Px1B2L4
124	000 – 255	Rosso: Px2B2L1 + Px2B2L2 + Px2B2L3 + Px2B2L4
125	000 – 255	Verde: Px2B2L1 + Px2B2L2 + Px2B2L3 + Px2B2L4
126	000 – 255	Blu: Px2B2L1 + Px2B2L2 + Px2B2L3 + Px2B2L4
...
238	000 – 255	Rosso: Px40B2L1 + Px40B2L2 + Px40B2L3 + Px40B2L4
239	000 – 255	Verde: Px40B2L1 + Px40B2L2 + Px40B2L3 + Px40B2L4
240	000 – 255	Blu: Px40B2L1 + Px40B2L2 + Px40B2L3 + Px40B2L4
241	000 – 255	Rosso: Px1B3L1 + Px1B3L2 + Px1B3L3 + Px1B3L4
242	000 – 255	Verde: Px1B3L1 + Px1B3L2 + Px1B3L3 + Px1B3L4
243	000 – 255	Blu: Px1B3L1 + Px1B3L2 + Px1B3L3 + Px1B3L4
244	000 – 255	Rosso: Px2B3L1 + Px2B3L2 + Px2B3L3 + Px2B3L4
245	000 – 255	Verde: Px2B3L1 + Px2B3L2 + Px2B3L3 + Px2B3L4
246	000 – 255	Blu: Px2B3L1 + Px2B3L2 + Px2B3L3 + Px2B3L4
...
358	000 – 255	Rosso: Px40B3L1 + Px40B3L2 + Px40B3L3 + Px40B3L4
359	000 – 255	Verde: Px40B3L1 + Px40B3L2 + Px40B3L3 + Px40B3L4
360	000 – 255	Blu: Px40B3L1 + Px40B3L2 + Px40B3L3 + Px40B3L4
361	000 – 255	Rosso: Px1B4L1 + Px1B4L2 + Px1B4L3 + Px1B4L4
362	000 – 255	Verde: Px1B4L1 + Px1B4L2 + Px1B4L3 + Px1B4L4
363	000 – 255	Blu: Px1B4L1 + Px1B4L2 + Px1B4L3 + Px1B4L4
364	000 – 255	Rosso: Px2B4L1 + Px2B4L2 + Px2B4L3 + Px2B4L4
365	000 – 255	Verde: Px2B4L1 + Px2B4L2 + Px2B4L3 + Px2B4L4
366	000 – 255	Blu: Px2B4L1 + Px2B4L2 + Px2B4L3 + Px2B4L4
...
478	000 – 255	Rosso: Px40B4L1 + Px40B4L2 + Px40B4L3 + Px40B4L4
479	000 – 255	Verde: Px40B4L1 + Px40B4L2 + Px40B4L3 + Px40B4L4
480	000 – 255	Blu: Px40B4L1 + Px40B4L2 + Px40B4L3 + Px40B4L4



DISEGNO 1

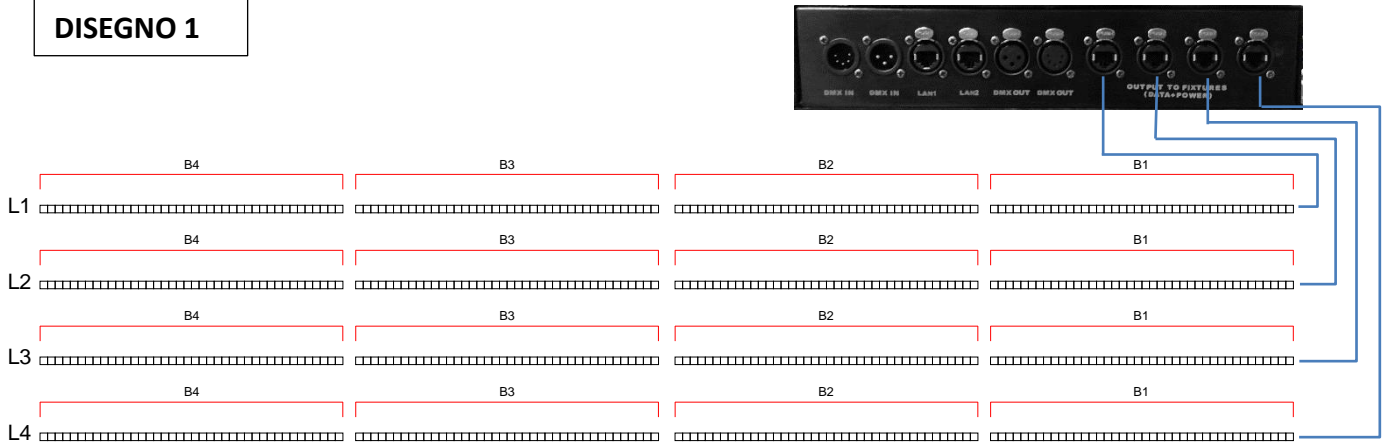

DISEGNO 2

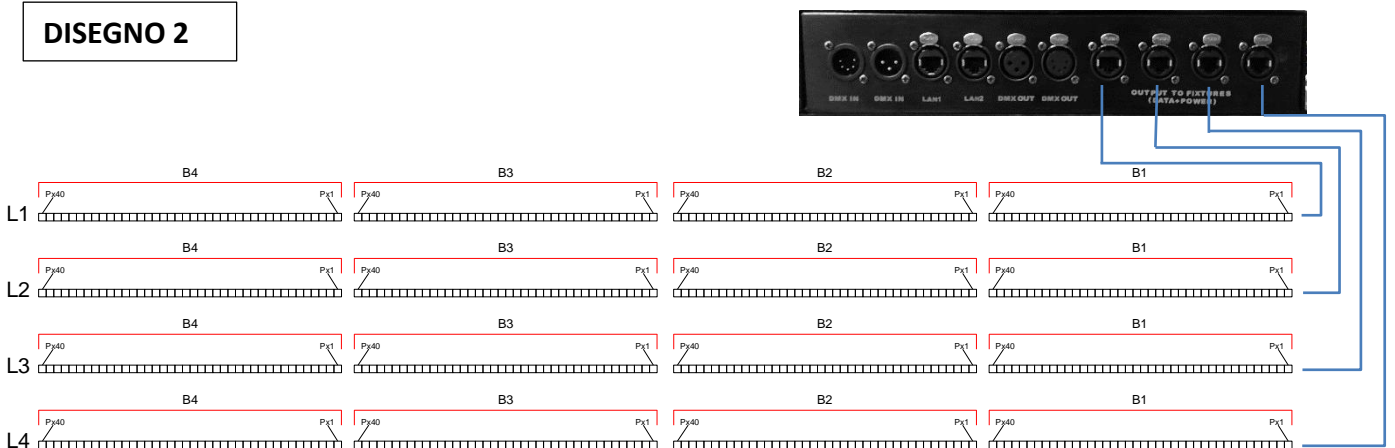

6. MANUTENZIONE

Per garantire ottime prestazioni, l'apparecchio deve essere pulito frequentemente. Scollegare l'apparecchio dalla corrente e lasciarlo raffreddare per almeno 35 minuti onde evitare il rischio di bruciature. Utilizzare un'aspirapolvere o compressore e una spazzola morbida o un panno per lenti per rimuovere la polvere depositata.

Le lenti, come qualsiasi altra parte eventualmente danneggiata, devono essere sostituite con ricambi originali.



7. SPECIFICHE TECNICHE

- Alimentazione: 100-240V, 50/60HZ
- LED: 40 SMD 5050 RGB (per ogni QPix Bar)
- Potenza assorbita: 400W con Qpix Bar BOX full (16 barre)
- Modalità operative: Auto, Master/Slave, DMX512, ArtNet
- Regolazione elettronica della luminosità 0-100%
- DMX: 7 – 16 – 48 – 82 – 480 canali
- ArtNet: 1920 canali
- Display digitale per impostazione indirizzo e funzioni
- Dimensioni QPix Bar (L x A x P): mm. 1000x40x95
- Dimensioni QPix Bar Box (L x A x P): mm. 290x205x85
- Peso QPix Bar kg 1,2
- Peso QPix Bar Box kg 4

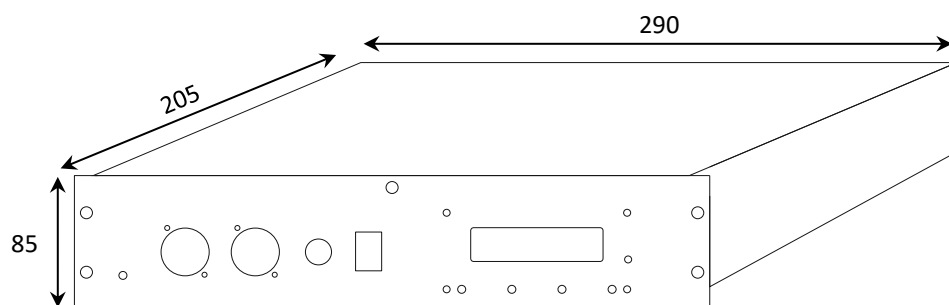
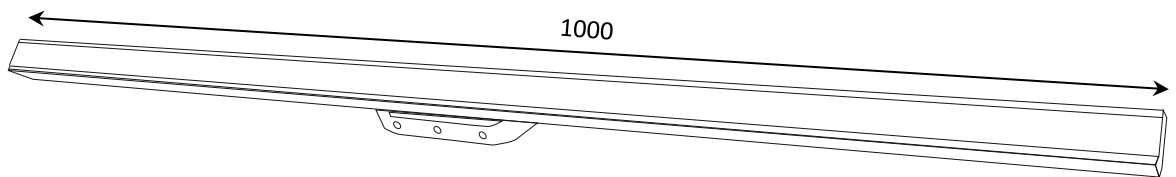



1. INTRODUCTION

Thank You for choosing one of Our products!

Please refer to the instructions and warnings contained in this user manual, please retain it for future reference.

This manual contains information about the installation and use of the device.

The information contained in this publication has been carefully prepared and checked. However it is not assumed any responsibility for any inaccuracies. All rights are reserved and this document can not be copied, photocopied, reproduced in whole or in part without previous written permission of PROEL. PROEL reserves the right to make, without notice, any aesthetical, functional or design changes or modifications in everyone of its products. PROEL doesn't assume any responsibility for the use or application of the products here described.



The crossed bin symbol, shown on the product or on accompanying documents, indicates that the product should not be disposed with other household waste at the end of the lifecycle. To avoid any damage to the environment, the user is encouraged to separate this product from other kinds of wastes and recycle it responsibly to promote the sustainable reuse of material resources. Home users are encouraged to contact the retailer where they purchased this product or their local government office for details on separate collection and recycling this type of product. Business users are encouraged to contact their supplier and check the terms and conditions of the purchase contract. This product should not be mixed with other commercial waste.



The lightning symbol with arrow in an equilateral triangle intends to alert the user to the presence of not insulated "dangerous voltages" within the product's enclosure that may be of sufficient magnitude to constitute a risk of electric shock to persons.



The exclamation point symbol within an equilateral triangle intends to alert the user to the presence of important instructions for use and maintenance on the accompanying documents of the product.



The "F" inside an equilateral reversed triangle means that the product is suitable for mounting on normally flammable surfaces.



The product to which this manual refers comply with the European Directives pursuant to the safety of electrical equipment supplied at low voltage (LVD) and to the Electromagnetic Compatibility (EMC)



2. SAFETY INSTRUCTIONS

Caution! This product is not suitable for household illumination.

Please read this manual before installing and applying power to the equipment, follow the safety precautions listed below and observe all warnings in this manual and printed on. Please contact a PROEL distributor for assistance with any questions about how to activate the equipment safely. Contact a qualified technician for any maintenance work not described in this manual.

Do not modify the fixture or install accessories and upgrade kits that are not the Proel original ones.

People involved in the installation and maintenance of the device must:

- Be qualified
- Follow the instructions of this manual in the theaters, in the halls, in the places where the events take place, etc.

CHECKS BEFORE INSTALLATION

Make sure all the parts for fixing the product are in good condition.

Make sure that the anchor point is stable before positioning the product.

The safety cable must be properly attached to the device and fixed to the supporting structure so that, in case of failure of the primary supporting system, it has the lowest possible fall of the device.

If the safety cable wear, must be replaced with an original spare.

MINIMUM DISTANCE OF ILLUMINATED OBJECTS

The projector must be positioned so that the objects hit by the beam of light are at least 2 meters from the lens of the projector.

MINIMUM DISTANCE FROM FLAMMABLE MATERIALS

The product must be positioned so that any flammable material is at least 0.50 meters from any point of the surface of the device. Never place filters or other materials over the lens or on the optical axis.

MOUNTING SURFACES

The device is suitable for mounting on normally flammable surfaces.

REFERENCE TEMPERATURE

The ambient temperature range of use of the device varies between + 5 ° C (min) and + 40 ° C (max), outside of that range the device should not be used.

The maximum temperature of the housing $T_b = 80$ ° C must never be exceeded. Do not block the exhaust fans, ensuring a minimum clearance of 0.5 meters around the ventilation holes.



IP20 PROTECTION RATING

The device is protected against the penetration of solid bodies larger than 12 mm (0,47 ") in diameter (first digit 2), but not against dripping water, rain, splashes or jets of water (second digit 0). Use only in dry areas. Inside use only. Do not expose the equipment to rain or moisture.

PROTECTION AGAIN ELECTRIC SHOCK

The device must be connected to a power supply system with efficient earthing. Moreover, it is recommended to protect power supply lines of the product from indirect contact and / or shorting to earth by using appropriately sized anti electrical shock switch.

CONNECTION TO THE MAINS

The electrical connection must be carried out by a qualified electrician.

Ensure that the mains frequency and voltage correspond to those for which the equipment is designed, as shown in the electrical data label. This label also shows the power consumption that is necessary to refer to evaluate the maximum number of devices to be connected to the electricity line, in order to avoid power overloading.

If the external power cord of this light is damaged, it must be replaced with a special cord exclusively available from Your PROEL dealer.

Never operate the equipment with lenses and / or covers missing or damaged.

In case of non-use, it is recommended to unplug the projector from the mains.

MAINTENANCE

Before starting any maintenance or cleaning the product, disconnect the power from the mains and disconnect the power cable from the device. After switching off, do not remove any part of the device for at least 35 minutes to avoid the risk of burns. The lenses, if damaged, must be replaced with original spare parts.

WARNING

CAUTION. Do not look directly at the light source. Do not look at the beam with lenses, glasses, mirrors or similar optical instruments that could change the convergence of light, causing serious damage to people and / or things.



WARNING! DANGER FOR THE EYES!

Do not look directly at the light source



3. OPENING AND CONTROL

Carefully open the package, check the content and make sure that all the parts are present and are in good condition. In cases where some parts are not present or are damaged, immediately contact Your supplier and retain the packaging for verification.

	<p>WARNING!</p> <p>If the product has been exposed to drastic temperature changes, let the unit turned off until it reaches room temperature because the presence of condensation can damage the product if it is turned on.</p>
--	---

Verify that the boxes contain the following items:

Scatola della barra :

- N° 1 SG QPIXBAR
- N°1 White frost filter
- N°1 Cat5 cable

Box of CONTROLLER :

- N° 1 SG QPIXBARBOX
- N°1 Power supply cable
- N°1 Cat5 cable
- N°1 DMX cable

BAR FRONT VIEW



1 – Black frost filter



BAR REAR VIEW



1 – Signal + Power IN
2 – Signal + Power OUT





CONTROLLER FRONT VIEW

1. Power IN
2. Power OUT
3. Fuse
4. ON/OFF switch
5. Display + buttons
6. DMX signal indicator

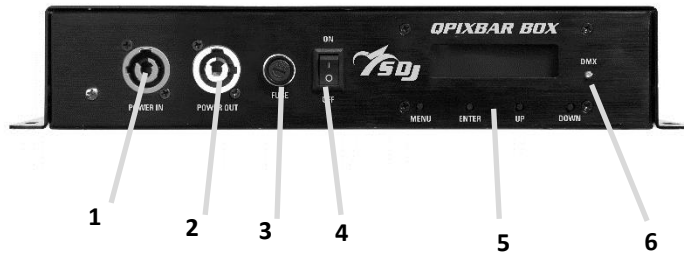

CONTROLLER REAR VIEW

1. DMX IN XLR 5 poles
2. DMX IN XLR 3 poles
3. ArtNet IN
4. DMX OUT XLR 3 poles
5. DMX OUT XLR 5 poles
6. Bar OUT A-B-C-D: signal + power (only bars)



	<p style="text-align: center;"><u>WARNING !!!</u></p> <p>Do not connect the ArtNet cable from PC or console to the Outputs A-B-C-D because in these outputs there is the VDC Power supply together with the signal of the bars.</p> <p>Accidental connection of the ArtNet cable of the PC or the console to one of the 4 outputs A-B-C-D can irreparably damage the PC or the console.</p>
--	--



4. INSTALLATION AND SWITCH ON

4.1 - PRODUCT INSTALLATION

- Do not shake the device. Avoid the use of too much force during installation or unit fixing.
- The unit can be installed on the wall, ceiling or on a truss.
- It is possible to generate different configurations by using following accessories (sold separately)

- IN CASE OF SUSPENSION ON THE WALL OR ON THE CEILING, EACH BAR MUST BE FIXED WITH ITS "C" BRACKET. IT IS NOT POSSIBLE TO REALIZE MATRIX, CONFIGURATIONS OR COLUMNS BY SUSPENDING THE BARS ONLY WITH THE FOLLOWING ACCESSORIES OR ACCESSORIES ALREADY INCLUDED



SG QPIXBARCK2
2-ways 90° connection



SG QPIXBARCK3
3-ways "T" connection



SG QPIXBARCK4
4-ways connection



SG QPIXBARCKV
Variable 2-ways connection



SG QIXBARBS
Base for 2 vertical bars



SG QPIXBARRWD
Rounded white diffuser

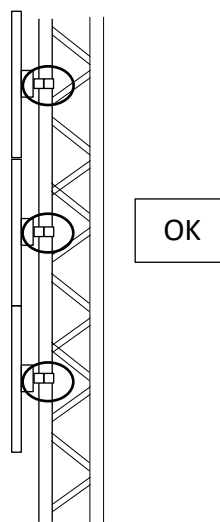
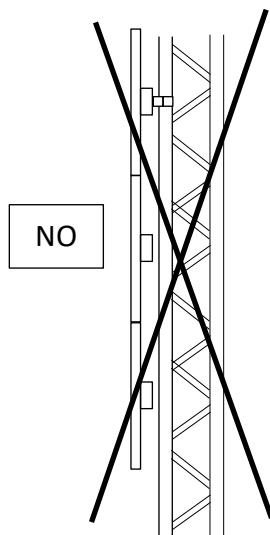

WARNING! IT'S REQUIRED

the mounting of the safety rope (PLH232 – PLH248 sold separately) in the case where the product is hung on a wall, ceiling or on a truss. Except when the device is placed in the floor, the safety cable is always required.



4.2 - CONNECTION TO THE MAINS

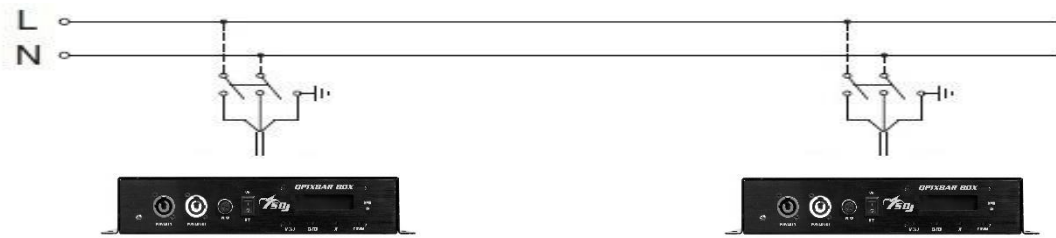

The device must be connected to a power supply system with a proper earth system. Moreover, it is recommended to protect power supply lines of the products from indirect contact and / or shorting to earth by using appropriately sized anti electrical shock switch. The electrical connection must be carried out by a qualified electrician. Ensure that the mains frequency and voltage correspond to those for which the device is designed, as shown in the electrical data label.

4.3 – CONNECTION TO THE DMX CHAIN

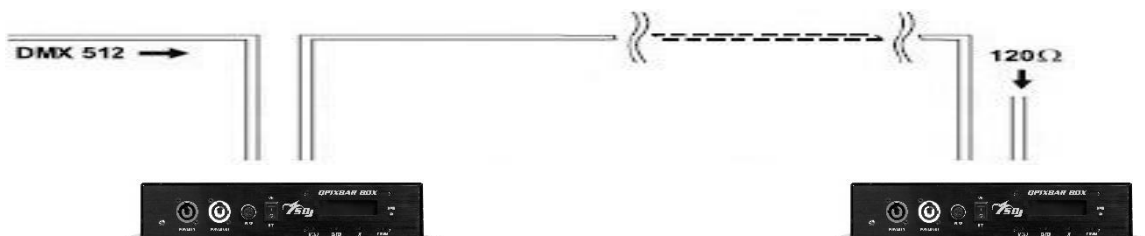

Use a cable conforming to specifications EIA RS-485: pole twisted, shielded, 120Ohm characteristic impedance and low capacity (SAGITTER SG DMX3 – SG DMX5). Do not use microphone cable or other cable with different characteristics than those specified. Terminations must be made with male / female XLR 3-pin connectors. You must enter on the last device a terminal plug with a 120Ohm resistance (min1 / 4 W) between terminals 2 and 3. **IMPORTANT:** The cables must not come into contact with each other or with the metal housing of the connectors. The housing itself must be connected to the shield braid and to pin 1 of the connectors.



5. SETUP

5.1 – MENU

Level	Function	Specifications	Description
1	DMX address	001 – 512	DMX addressing
2	DMX mode	CH7 / CH16 / CH48 / CH82 / CH480	DMX channels mode
3	Auto mode	Speed 1 – 9	Speed of internal program
		Program 1 – 30	Setting of internal program
4	Slave mode	YES / NO	Set Slave mode
5	Network settings	IP address: 0.0.0.0 – 255.255.255.255	ArtNet settings
		Subnet mask: 0.0.0.0 – 255.255.255.255	
		Net subnet univers: 000.00.00 – 255.15.15	
6	ArtNet Output	A	ArtNet outputs
		A+B	
		A+B+C	
		A+B+C+D	
7	System reset	Reset	Reset
8	Software version	QPIXBAR V1.0	Software version

5.2 – MASTER/SLAVE MODE

In this mode, more units can be linked together as a single chain and work in a synchronized way.

- Use a DMX cable to link together all the units from the connector DMX OUT to DMX IN.
- Define the first unit of the chain as MASTER, all other units must be set in SLAVE MODE = YES.
- Operate the Master unit in Automatic mode (Auto mode) to operate the entire system. The entire chain of Slave unit will act as the Master unit.



5.3 – DMX MODE

7 Channels mode

CH	Values	Description
1	000 - 255	Master dimmer
2	000 - 255	Strobe from slow to fast
3	000 - 255	Red (all the bars)
4	000 - 255	Green (all the bars)
5	000 - 255	Blue (all the bars)
6	000 - 255	Auto programs from 1 to 30
7	000 - 255	Auto programs speed

16 Channels mode (ref. drawing 1)

CH	Values	Description
1	000 – 255	Master dimmer
2	000 – 255	Strobe from slow to fast
3	000 – 255	RED: B1L1 + B1L2 + B1L3 + B1L4
4	000 – 255	GREEN: B1L1 + B1L2 + B1L3 + B1L4
5	000 – 255	BLUE: B1L1 + B1L2 + B1L3 + B1L4
6	000 – 255	RED: B2L1 + B2L2 + B2L3 + B2L4
7	000 – 255	GREEN: B2L1 + B2L2 + B2L3 + B2L4
8	000 – 255	BLUE: B2L1 + B2L2 + B2L3 + B2L4
9	000 – 255	RED: B3L1 + B3L2 + B3L3 + B3L4
10	000 – 255	GREEN: B3L1 + B3L2 + B3L3 + B3L4
11	000 – 255	BLUE: B3L1 + B3L2 + B3L3 + B3L4
12	000 – 255	RED: B4L1 + B4L2 + B4L3 + B4L4
13	000 – 255	GREEN: B4L1 + B4L2 + B4L3 + B4L4
14	000 – 255	BLUE: B4L1 + B4L2 + B4L3 + B4L4
15	000 – 255	Auto programs from 1 to 30
16	000 – 255	Auto programs speed

48 Channels mode (ref. drawing 1)

CH	Values	Description
1	000 – 255	RED: B1L1
2	000 – 255	GREEN: B1L1
3	000 – 255	BLUE: B1L1
4	000 – 255	RED: B2L1
5	000 – 255	GREEN: B2L1
6	000 – 255	BLUE: B2L1
7	000 – 255	RED: B3L1
8	000 – 255	GREEN: B3L1
9	000 – 255	BLUE: B3L1
10	000 – 255	RED: B4L1
11	000 – 255	GREEN: B4L1
12	000 – 255	BLUE: B4L1
13	000 – 255	RED: B1L2
14	000 – 255	GREEN: B1L2
15	000 – 255	BLUE: B1L2
16	000 – 255	RED: B2L2
17	000 – 255	GREEN: B2L2
18	000 – 255	BLUE: B2L2
19	000 – 255	RED: B3L2
20	000 – 255	GREEN: B3L2



21	000 – 255	BLUE: B3L2
22	000 – 255	RED: B4L2
23	000 – 255	GREEN: B4L2
24	000 – 255	BLUE: B4L2
25	000 – 255	RED: B1L3
26	000 – 255	GREEN: B1L3
27	000 – 255	BLUE: B1L3
28	000 – 255	RED: B2L3
29	000 – 255	GREEN: B2L3
30	000 – 255	BLUE: B2L3
31	000 – 255	RED: B3L3
32	000 – 255	GREEN: B3L3
33	000 – 255	BLUE: B3L3
34	000 – 255	RED: B4L3
35	000 – 255	GREEN: B4L3
36	000 – 255	BLUE: B4L3
37	000 – 255	RED: B1L4
38	000 – 255	GREEN: B1L4
39	000 – 255	BLUE: B1L4
40	000 – 255	RED: B2L4
41	000 – 255	GREEN: B2L4
42	000 – 255	BLUE: B2L4
43	000 – 255	RED: B3L4
44	000 – 255	GREEN: B3L4
45	000 – 255	BLUE: B3L4
46	000 – 255	RED: B4L4
47	000 – 255	GREEN: B4L4
48	000 – 255	BLUE: B4L4

82 Channels mode (ref. drawing 1)

CH	Values	Description
1	000 – 255	Master dimmer B1L1
2	000 – 255	Strobe from slow to fast B1L1
3	000 – 255	RED: B1L1
4	000 – 255	GREEN: B1L1
5	000 – 255	BLUE: B1L1
6	000 – 255	Master dimmer B2L1
7	000 – 255	Strobe from slow to fast B2L1
8	000 – 255	RED: B2L1
9	000 – 255	GREEN: B2L1
10	000 – 255	BLUE: B2L1
11	000 – 255	Master dimmer B3L1
12	000 – 255	Strobe from slow to fast B3L1
13	000 – 255	RED: B3L1
14	000 – 255	GREEN: B3L1
15	000 – 255	BLUE: B3L1
16	000 – 255	Master dimmer B4L1
17	000 – 255	Strobe from slow to fast B4L1
18	000 – 255	RED: B4L1
19	000 – 255	GREEN: B4L1
20	000 – 255	BLUE: B4L1
21	000 – 255	Master dimmer B1L2



22	000 – 255	Strobe from slow to fast B1L2
23	000 – 255	RED: B1L2
24	000 – 255	GREEN: B1L2
25	000 – 255	BLUE: B1L2
26	000 – 255	Master dimmer B2L2
27	000 – 255	Strobe from slow to fast 2B2L2
28	000 – 255	RED: B2L2
29	000 – 255	GREEN: B2L2
30	000 – 255	BLUE: B2L2
31	000 – 255	Master dimmer B3L2
32	000 – 255	Strobe from slow to fast B3L2
33	000 – 255	RED: B3L2
34	000 – 255	GREEN: B3L2
35	000 – 255	BLUE: B3L2
36	000 – 255	Master dimmer B4L2
37	000 – 255	Strobe from slow to fast B4L2
38	000 – 255	RED: B4L2
39	000 – 255	GREEN: B4L2
40	000 – 255	BLUE: B4L2
41	000 – 255	Master dimmer B1L3
42	000 – 255	Strobe from slow to fast B1L3
43	000 – 255	RED: B1L3
44	000 – 255	GREEN: B1L3
45	000 – 255	BLUE: B1L3
46	000 – 255	Master dimmer B2L3
47	000 – 255	Strobe from slow to fast B2L3
48	000 – 255	RED: B2L3
49	000 – 255	GREEN: B2L3
50	000 – 255	BLUE: B2L3
51	000 – 255	Master dimmer B3L3
52	000 – 255	Strobe from slow to fast B3L3
53	000 – 255	RED: B3L3
54	000 – 255	GREEN: B3L3
55	000 – 255	BLUE: B3L3
56	000 – 255	Master dimmer B4L3
57	000 – 255	Strobe from slow to fast B4L3
58	000 – 255	RED: B4L3
59	000 – 255	GREEN: B4L3
60	000 – 255	BLUE: B4L3
61	000 – 255	Master dimmer B1L4
62	000 – 255	Strobe from slow to fast B1L4
63	000 – 255	RED: B1L4
64	000 – 255	GREEN: B1L4
65	000 – 255	BLUE: B1L4
66	000 – 255	Master dimmer B2L4
67	000 – 255	Strobe from slow to fast B2L4
68	000 – 255	RED: B2L4
69	000 – 255	GREEN: B2L4
70	000 – 255	BLUE: B2L4
71	000 – 255	Master dimmer B3L4
72	000 – 255	Strobe from slow to fast B3L4
73	000 – 255	RED: B3L4
74	000 – 255	GREEN: B3L4



75	000 – 255	BLUE: B3L4
76	000 – 255	Master dimmer B4L4
77	000 – 255	Strobe from slow to fast B4L4
78	000 – 255	RED: B4L4
79	000 – 255	GREEN: B4L4
80	000 – 255	BLUE: B4L4
81	000 – 255	Auto programs from 1 to 30
82	000 – 255	Auto programs speed

480 Channels mode (ref. drawing 2)

CH	Values	Description
1	000 – 255	RED: Px1B1L1 + Px1B1L2 + Px1B1L3 + Px1B1L4
2	000 – 255	GREEN: Px1B1L1 + Px1B1L2 + Px1B1L3 + Px1B1L4
3	000 – 255	BLUE: Px1B1L1 + Px1B1L2 + Px1B1L3 + Px1B1L4
4	000 – 255	RED: Px2B1L1 + Px2B1L2 + Px2B1L3 + Px2B1L4
5	000 – 255	GREEN: Px2B1L1 + Px2B1L2 + Px2B1L3 + Px2B1L4
6	000 – 255	BLUE: Px2B1L1 + Px2B1L2 + Px2B1L3 + Px2B1L4
...
118	000 – 255	RED: Px40B1L1 + Px40B1L2 + Px40B1L3 + Px40B1L4
119	000 – 255	GREEN: Px40B1L1 + Px40B1L2 + Px40B1L3 + Px40B1L4
120	000 – 255	BLUE: Px40B1L1 + Px40B1L2 + Px40B1L3 + Px40B1L4
121	000 – 255	RED: Px1B2L1 + Px1B2L2 + Px1B2L3 + Px1B2L4
122	000 – 255	GREEN: Px1B2L1 + Px1B2L2 + Px1B2L3 + Px1B2L4
123	000 – 255	BLUE: Px1B2L1 + Px1B2L2 + Px1B2L3 + Px1B2L4
124	000 – 255	RED: Px2B2L1 + Px2B2L2 + Px2B2L3 + Px2B2L4
125	000 – 255	GREEN: Px2B2L1 + Px2B2L2 + Px2B2L3 + Px2B2L4
126	000 – 255	BLUE: Px2B2L1 + Px2B2L2 + Px2B2L3 + Px2B2L4
...
238	000 – 255	RED: Px40B2L1 + Px40B2L2 + Px40B2L3 + Px40B2L4
239	000 – 255	GREEN: Px40B2L1 + Px40B2L2 + Px40B2L3 + Px40B2L4
240	000 – 255	BLUE: Px40B2L1 + Px40B2L2 + Px40B2L3 + Px40B2L4
241	000 – 255	RED: Px1B3L1 + Px1B3L2 + Px1B3L3 + Px1B3L4
242	000 – 255	GREEN: Px1B3L1 + Px1B3L2 + Px1B3L3 + Px1B3L4
243	000 – 255	BLUE: Px1B3L1 + Px1B3L2 + Px1B3L3 + Px1B3L4
244	000 – 255	RED: Px2B3L1 + Px2B3L2 + Px2B3L3 + Px2B3L4
245	000 – 255	GREEN: Px2B3L1 + Px2B3L2 + Px2B3L3 + Px2B3L4
246	000 – 255	BLUE: Px2B3L1 + Px2B3L2 + Px2B3L3 + Px2B3L4
...
358	000 – 255	RED: Px40B3L1 + Px40B3L2 + Px40B3L3 + Px40B3L4
359	000 – 255	GREEN: Px40B3L1 + Px40B3L2 + Px40B3L3 + Px40B3L4
360	000 – 255	BLUE: Px40B3L1 + Px40B3L2 + Px40B3L3 + Px40B3L4
361	000 – 255	RED: Px1B4L1 + Px1B4L2 + Px1B4L3 + Px1B4L4
362	000 – 255	GREEN: Px1B4L1 + Px1B4L2 + Px1B4L3 + Px1B4L4
363	000 – 255	BLUE: Px1B4L1 + Px1B4L2 + Px1B4L3 + Px1B4L4
364	000 – 255	RED: Px2B4L1 + Px2B4L2 + Px2B4L3 + Px2B4L4
365	000 – 255	GREEN: Px2B4L1 + Px2B4L2 + Px2B4L3 + Px2B4L4
366	000 – 255	BLUE: Px2B4L1 + Px2B4L2 + Px2B4L3 + Px2B4L4
...
478	000 – 255	RED: Px40B4L1 + Px40B4L2 + Px40B4L3 + Px40B4L4
479	000 – 255	GREEN: Px40B4L1 + Px40B4L2 + Px40B4L3 + Px40B4L4
480	000 – 255	BLUE: Px40B4L1 + Px40B4L2 + Px40B4L3 + Px40B4L4



DRAWING 1

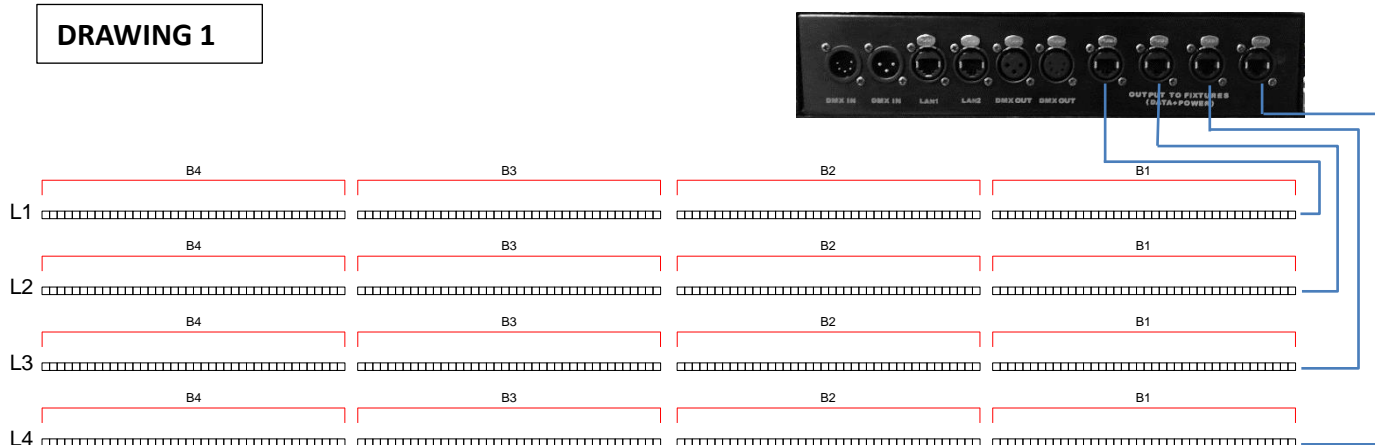

DRAWING 2

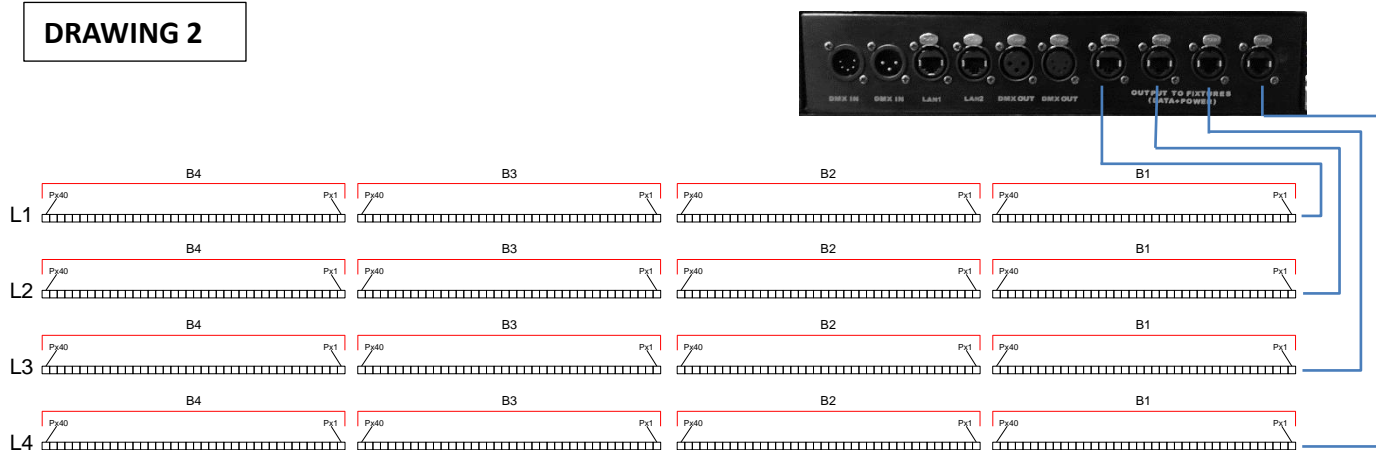

6. MAINTENANCE

To ensure optimal performance, the unit must be frequently cleaned. Unplug the device from the mains and let it cool for at least 35 minutes to avoid the risk of burns. Use a vacuum cleaner or an air compressor and a soft brush or a lens cloth to remove the dust deposited. The lenses, like any other damaged part, must be replaced with original spare parts.



7. TECHNICAL SPECIFICATIONS

- Power Supply: 100-240V, 50/60HZ
- LED: 40 SMD 5050 RGB (for each one QPix Bar)
- Power consumption: 400W with QPix Bar BOX full (16 bar)
- Operation Mode: Auto, Master/Slave, DMX512, ArtNet
- Electronic Dimming 0-100%
- DMX 7 – 16 – 48 – 82 – 480 Channels
- ArtNet: 1920 channels
- Digital display for address and function setting
- Dimensions QPix Bar (L x H x D): mm. 1000x40x95
- Dimensions QPix Bar Box (L x H x D): mm. 290x205x85
- Weight QPix Bar: kg 1,2
- Weight QPix Bar Box: kg 4

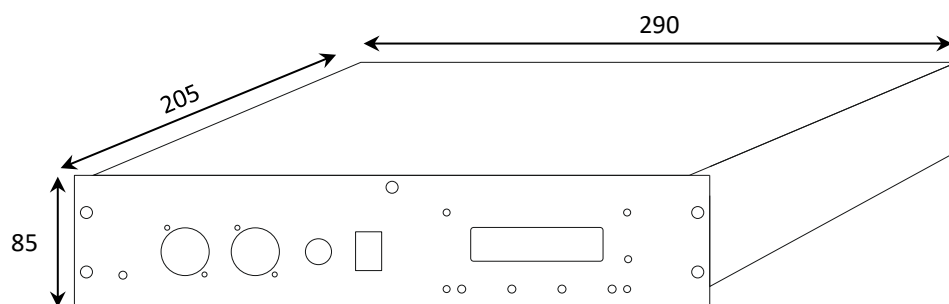
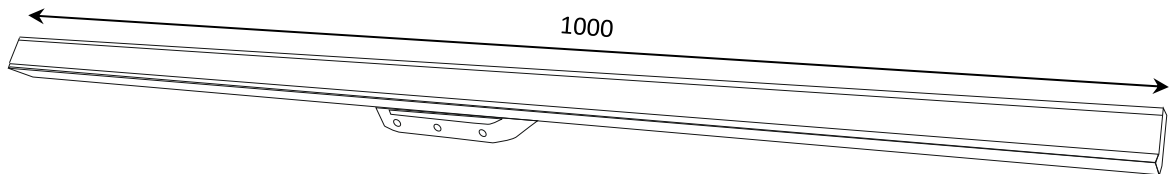





is a brand of PROEL SPA
(Worldwide Headquarters)
Via alla Ruena, 37/43
64027 Sant'Omero (TE) - ITALY
Tel. +39 0861 81241
Fax +39 0861 887862
P.I. 00778590679
N.Reg.AEE IT 08020000002762

sagitter.com